



# UNIC-ST-PRO-2000 AIR BLAST SPRAYER

SPARE PARTS



SPRAYER N°: .....

MANUF. YEAR: .....



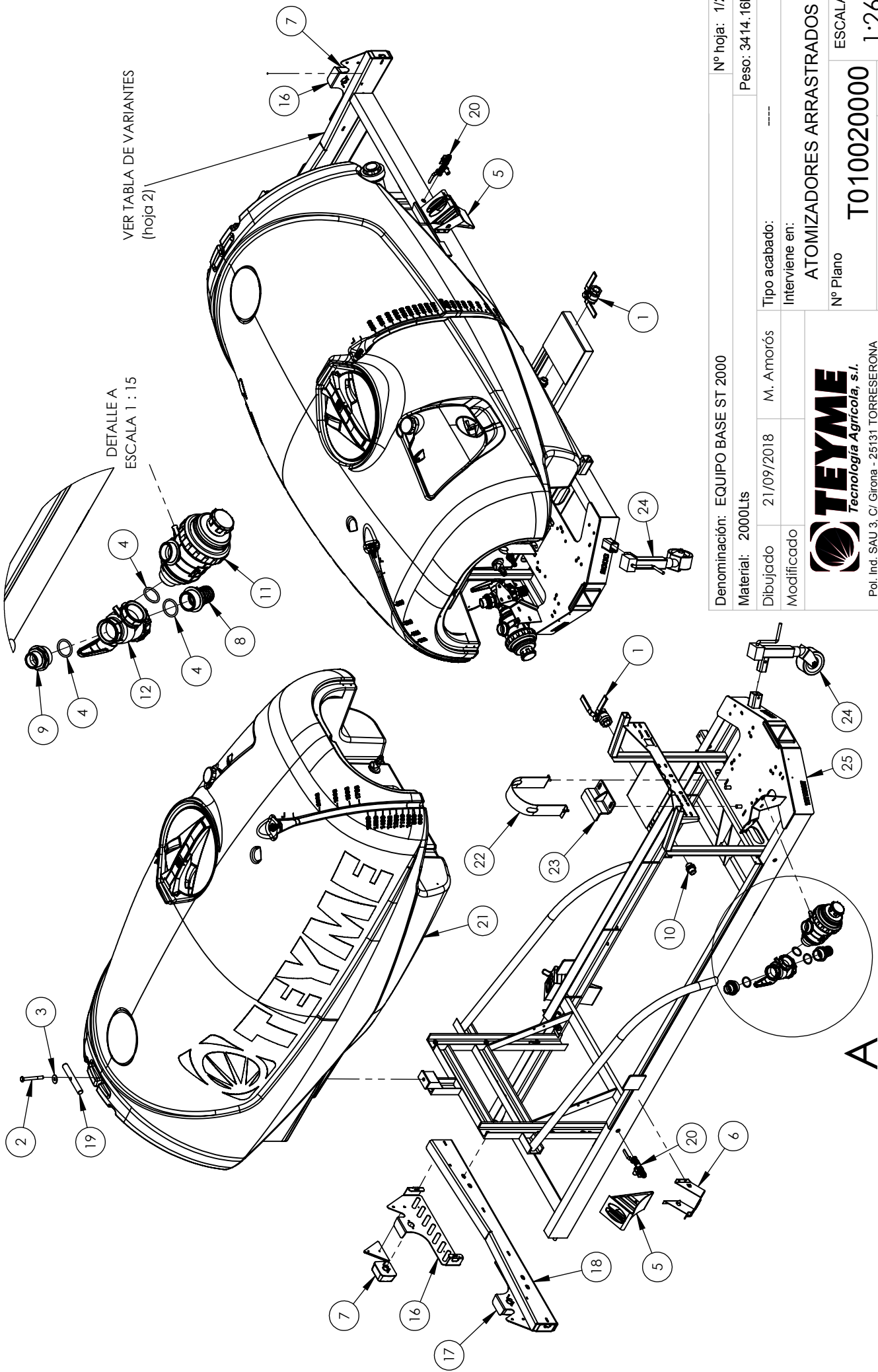

VER TABLA DE VARIANTES  
(hoja 2)

DETALLE A  
ESCALA 1 : 15

Denominación: EQUIPO BASE ST 2000		Nº hoja: 1/2
Material: 2000Lts		Peso: 3414,16kg
Dibujado: 21/09/2018	M. Amorós	
Modificado:		
Tipo acabado:		
Interviene en:		
Nº Plano		T010020000
Proceso		Montaje
Versión		00
 <b>TEYME</b> Tecnología Agrícola, s.l. Pol. Ind. SAU 3, C/ Girona - 25131 TORRESERONA (Lleida) - SPAIN Telf. 973 750 033 - Fax. 973 751 581 www.teyme.es - e-mail: comercial@teyme.es		ESCALA 1:26

Cotas sin tolerancia según ISO2768-1 en grado m (medio)  
 Suavizar aristas

Este plano es propiedad de TEYME Tecnología Agrícola, S.L. Prohibida su reproducción y cesión a terceros.

## UNIC-ST-2000 FRAME

Nº	CODE	DESCRIPTION
1	0170020006	1" FF BALL VALVFE
2	0500201412	DIN931 8.8 M14x120 SCREW
3	0550150014	DIN-9021 M14 WIDE FLAT WASHER
4	0790010013	ØINT.45x5 GASKET
5	1000900022	TYPE 360 CHOCK
6	1000900023	TYPE 360 CHOCK HOLDER
7	2331000198	LED LIGHTS KIT F/GTS9-I GTE9-I AIR UNIT
8	A001032750	M 2" Ø50 STRAIGHT FITTING HOSE-HOLDER
9	A002402076	P.P. M 2" - M 1 1/2" REDUCTION
10	A002502040	1 SYMMETRICAL NIPPLE
11	A003162472	316 SUCTION FILTER W/VALV M 2" R27mm RED 32M INOX
12	A0045521117	P.P. 2" 3-WAY BALL VALVE
16	T010341012	LEFT HOLDER FOR LIGHTS KIT LARGE IMMATRICULATION
17	T010341012S	RIGHT HOLDER FOR LIGHTS KIT LARGE IMMATRICULATION
18	T010341022	SIMPLE BUMPER BASE
19	T010720001	REAR UPPER TANK FIXATION
20	2400140469	THREE GUNS TAP KIT
21	T010100000	528 GAL MAIN TANK + CLEAN WATER TANK
22	2400048218	PTO PUMP PROTECTION PLATE KIT C
23	2400049079	TANK HOLDING CLAMP
24	2400049113	JACKWHEEL KIT FOR FRAME
25	T010221001	WELDED FRAME ST

N	N_pieza	Denominación	Cant.	Proceso	Peso
1	VZL1FOLM121	CISTERNA LAVAMANOS DEPOSITO 2000 L VERZELLES!	1	Compra Std	17.70
2	T010700000	SCJTO DEPOSITO 2000 VERZ - TEYME 2018	1	Montaje	2211.77
3	T010700001	SCJTO SUBDEPOSITO 2000 VERZ - TEYME 2018	1	Montaje	857.69

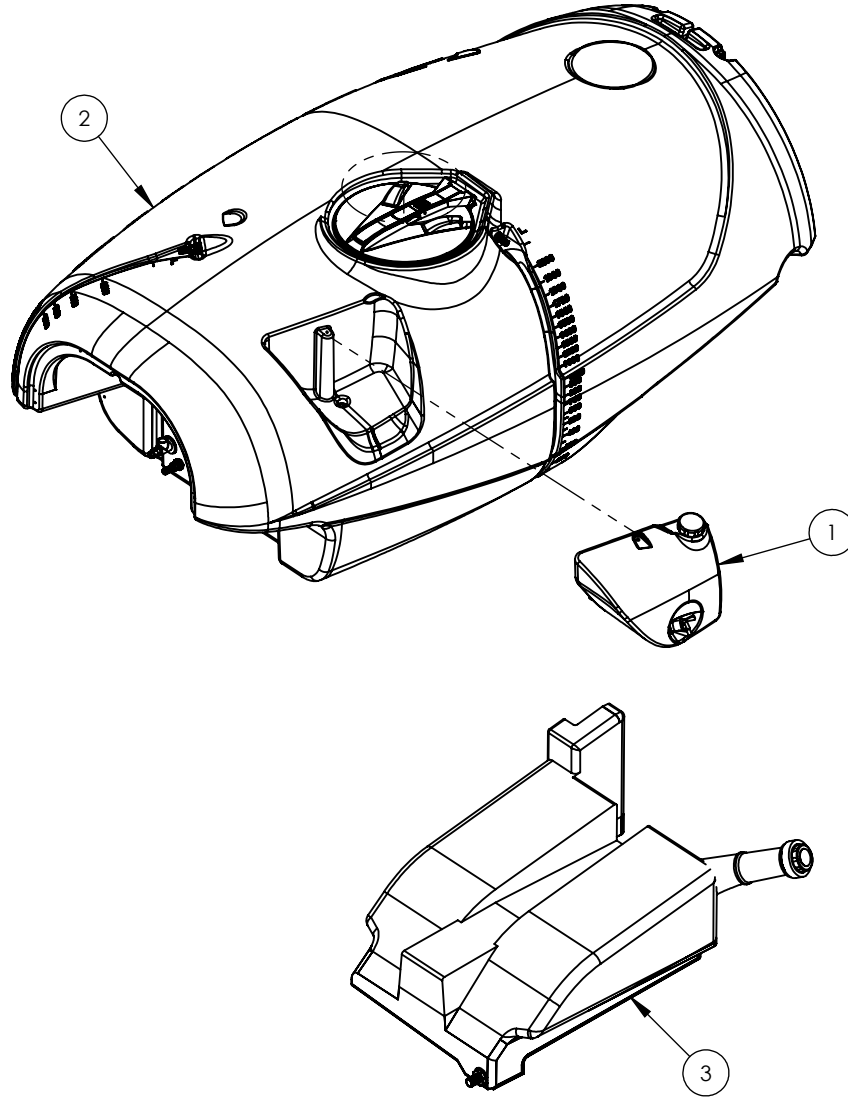

Denominación: CJTO DEPOSITO + SUBDEPOSITO 2000 VERZ - TEYME			Nº hoja: 1/1
Material: 2000Lts <sup>2018</sup>			Peso: 3087.16kg
Dibujado	06/09/2018	M. Amorós	Tipo acabado: ----
Modificado			Interviene en: ATOMIZADORES ARRASTRADOS
 Pol. Ind. SAU 3, C/ Girona - 25131 TORRESERONA (Leida) - SPAIN Telf. 973 750 033 - Fax. 973 751 581 www.teyme.es - e-mail: comercial@teyme.es			Nº Plano <b>T010100000</b>
			Proceso <b>Montaje</b>
ESCALA <b>1:25</b>			

Suavizar aristas  
 Cotas sin tolerancia según ISO2768-1 en grado m (medio)

## 528 GAL TANK KIT

Nº	CODE	DESCRIPTION
1	VZL1FOLM121	SANITARY WATER TANK FOR 528 GAL TANK VERZELLES
2	T010700000	MAIN 528 GAL TANK
3	T010700001	RINSING TANK VERZ - TEYME

N	N_pieza	Denominación	Cant.	Proceso	Peso
1	0020120001	TUERCA PP 1/2"	5	Compra Std	0.01
2	0020120005	TUERCA P.P. 1 1/2"	1	Compra Std	0.02
3	0020120006	TUERCA PP 2"	1	Compra Std	0.04
4	0020150004	RACOR DESAGUE P.P. 1 1/2"	1	Compra Std	0.04
5	0020200010	UNION P.P. M-M 2" 51x24	1	Compra Std	0.12
6	0090020002	AGITADOR HID. EUROMIX STANDARD Ø2,5 mm.	2	Compra Std	1.91
7	0140060012	VALVULA ANTIRRETORNO LATON HH 1/2"	1	Compra Std	0.10
8	0790010060	JUNTA TORICA P/R 2. 40X2.5	2	Compra Std	0.00
9	0790060010	JUNTA PLANA SILICONA 1/2	4	Compra Std	0.01
10	0790060030	JUNTA PLANA SILICONA 1 1/2 NBR 47.50X64X3	1	Compra Std	0.00
11	0790060040	JUNTA PLANA NEGRA 2"	1	Compra Std	0.01
12	A00100219	RACOR RECTO P.P. 1/2" H Ø19	3	Compra Std	0.01
13	A001032220	RACOR PORTAMANGUERA MACHO 1/2" Ø20	1	Compra Std	0.01
14	A001191750	CODO Ø50 MACHO T7	1	Compra Std	0.21
15	A002502021	UNION PASAPARED P.P. M-M 1/2" 38x18	4	Compra Std	0.02
16	A00300130	FILTRO FORMA DE SACO 18 MESH Ø400 380x275mm LARGO	1	Compra Std	1.39
17	A00356061	COPERCHIO RIBALT. D.455 S.P.+BLOCCO	1	Compra Std	0.32
18	VZL1E911TRC21	DEPOSITO ARRAS 2000L MOD.IEYME-2018 GRIS7038 CMPRA	1	Compra Std	2204.89
19	0090010007	MEZCLADOR DE FONDO BOT MIX'BOQ.2,5	1	Montaje	0.64

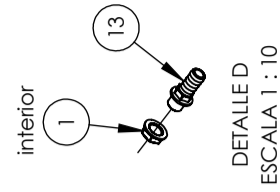
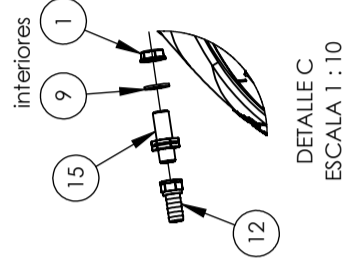
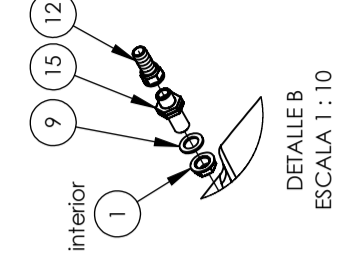
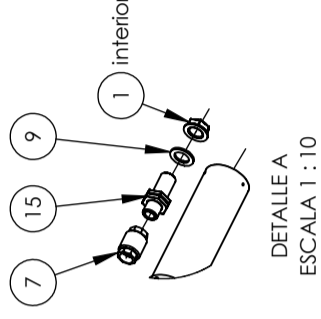
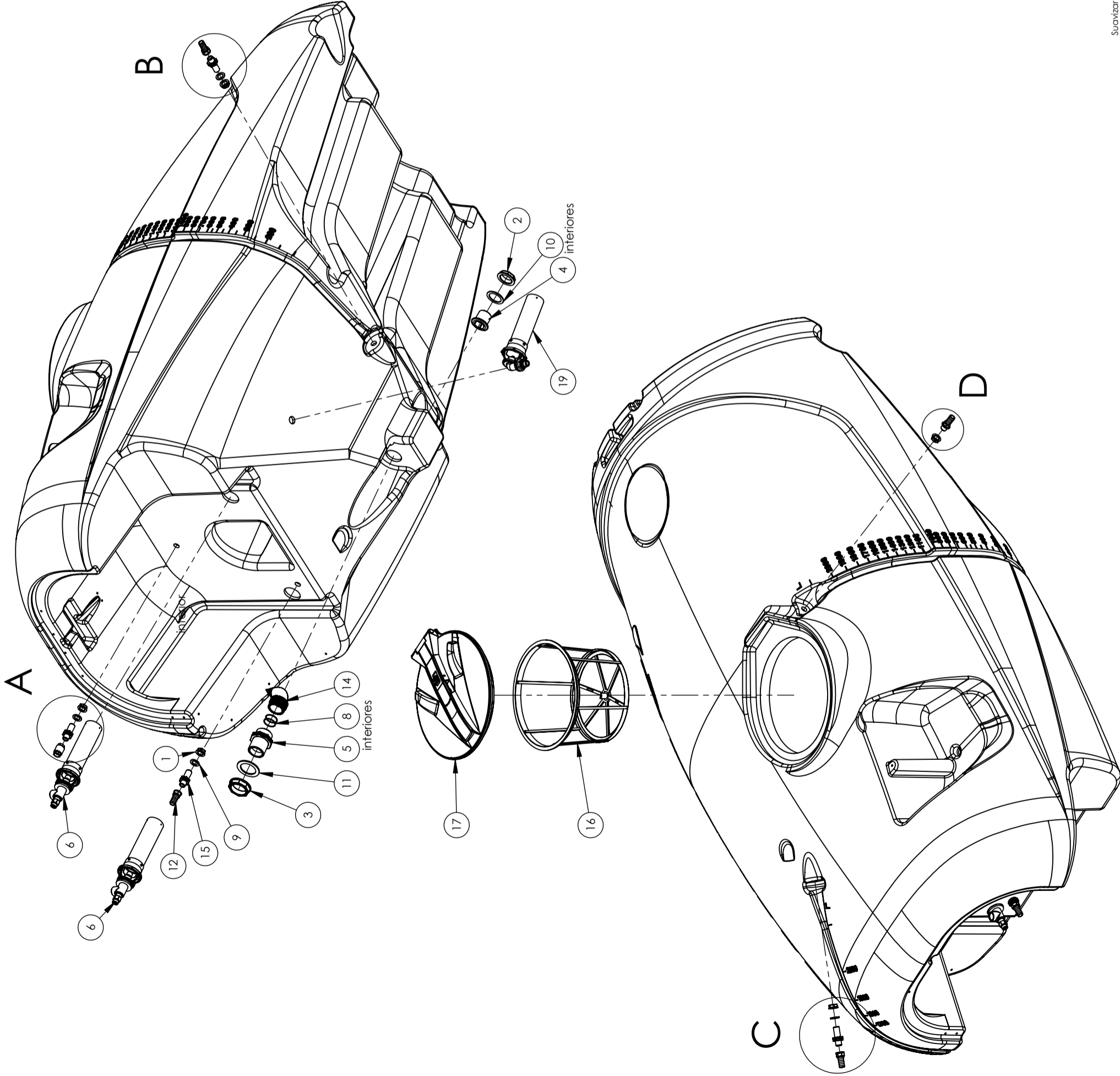

Denominación: SCJTO DEPOSITO 2000 VERZ - TEYME 2018 N° hoja: 1/1

Material: 2000Lts Peso: 2211.77kg

Dibujado: 06/09/2018 M. Amorós Tipo acabado: ----

Modificado: Interviene en:

**TEYME**  
Tecnología Agrícola, s.l.  
(Lleida) - SPAIN  
Pol. Ind. SAU 3, C/ Girona - 25131 TORRESERONA  
Telf. 973 750 033 - Fax. 973 751 681  
www.teyme.es - e-mail: comercial@teyme.es

ATOMIZADORES ARRASTRADOS

N° Plano: T010700000 ESCALA 1:15

Proceso: Montaje Versión: 00

## 528 GAL TANK

Nº	CODE	DESCRIPTION
1	0020120001	PP 1/2" NUT
2	0020120005	P.P. 1 1/2" NUT
3	0020120006	PP 2" NUT
4	0020150004	P.P. 1 1/2"DRAIN HOSE FITTING
5	0020200010	P.P. M-M 2" 51x24 UNION
6	0090020002	HID. EUROMIX STANDARD Ø2,5 mm STIRRER
7	0140060012	BRASS F-F 1/2"ANTI-RETURN VALVE
8	0790010060	P/R 2 40X2,5 GASKET
9	0790060010	1/2 FLAT GASKET
10	0790060030	1 1/2 NBR 47.50X64X3 FLAT GASKET
11	0790060040	2"BLACK FLAT GASKET
12	A00100219	P.P. 1/2" F Ø19 STRAIGHT FITTING
13	A001032220	MALE HOSE-HOLDER 1/2" Ø20 FITTING
14	A001191750	MALE Ø50 T7 ELBOW
15	A002502021	P.P. M-M 1/2" 38x18 BULKHEAD UNION
16	A00300130	18 MESH Ø400 380x275mm TANK FILLING FILTER
17	A00356061	D.455 S.P.COLLAPSIBLE LID
18	VZL1E91TRC21	TEYME MODEL TRAILED 528 GAL GREY 7038 TANK
19	0090010007	"BOT MIX"BOQ.2,5 BOTTOM STIRRER



N	N_pieza	Denominación	Cant.	Proceso	Peso
1	1100010201	SUBDEPOSITO-ARRAS.POLIET. 200 L C/TUBO -GRIS 7037	1	Compra Std	857.29
2	A001032630	RACOR RECTO P.P. M 1 1/2" Ø30	1	Compra Std	0.36
3	GE08178008	TAPON LAVAMANOS/SUBDEP. 200L Ø80	1	Compra Std	0.04

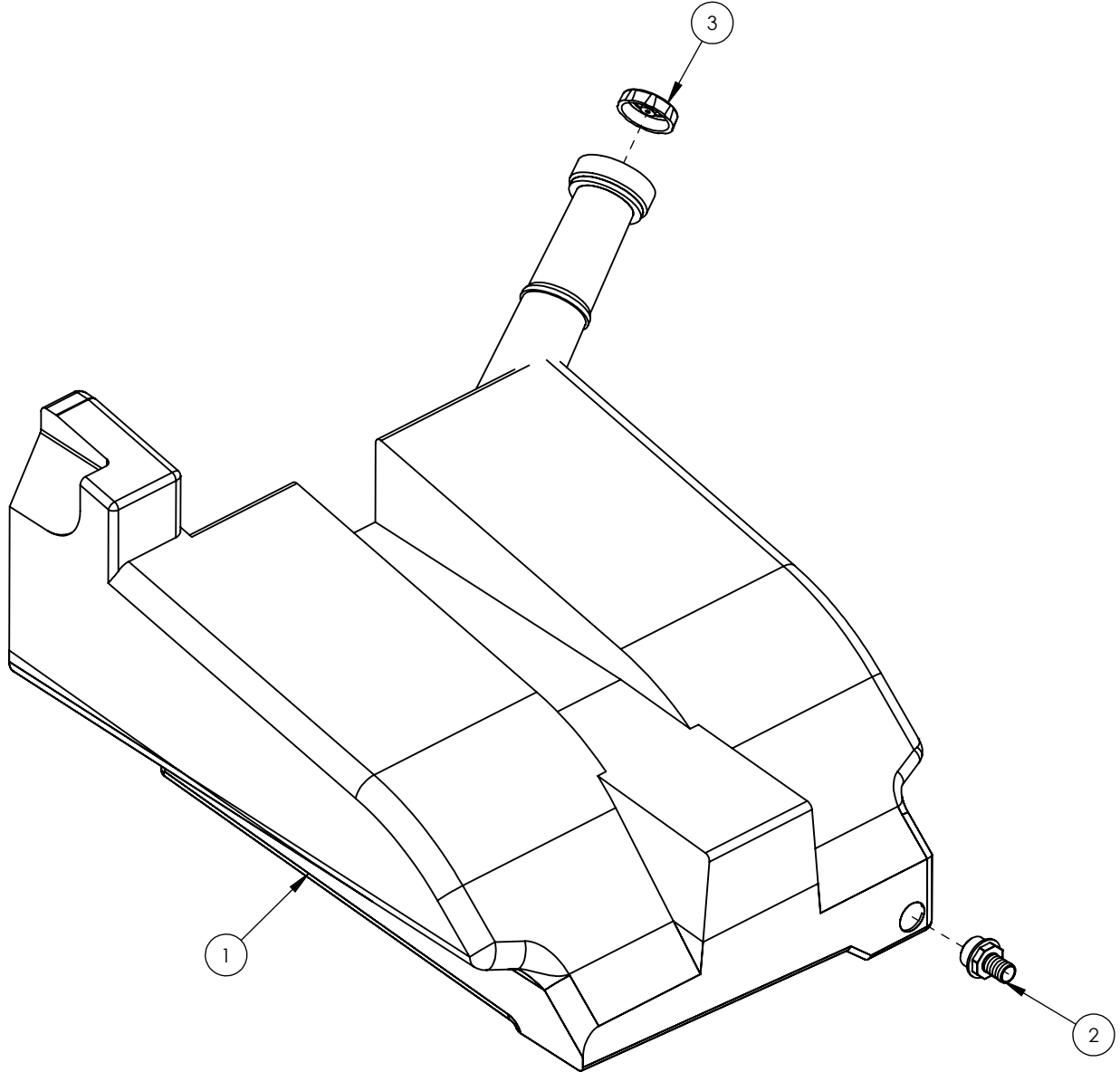

Denominación: SCJTO SUBDEPOSITO 2000 VERZ - TEYME 2018			Nº hoja: 1/1		
Material: 200Lts			Peso: 857.69kg		
Dibujado	06/09/2018	M. Amorós	Tipo acabado: ----		
Modificado			Interviene en: ATOMIZADORES ARRASTRADOS		
 Pol. Ind. SAU 3, C/ Girona - 25131 TORRESERONA (Leida) - SPAIN Telf. 973 750 033 - Fax. 973 751 581 www.teyme.es - e-mail: comercial@teyme.es			Nº Plano	ESCALA	
			T010700001		1:10
			Proceso	Versión	
			Montaje	00	

Suavizar aristas  
 Cotas sin tolerancia según ISO2768-1 en grado m (medio)

## 528 GAL CLEAN WATER TANK

Nº	CODE	DESCRIPTION
1	1100010201	TRAILED POLYETHYLENE 52 GAL TANK W/TUBE - 7037 GREY
2	A001032630	P.P. M 1 1/2" Ø30 STRAIGHT FITTING
3	GE08178008	CAP FOR SANITARY WATER TANK/ 52 GAL TANK Ø80

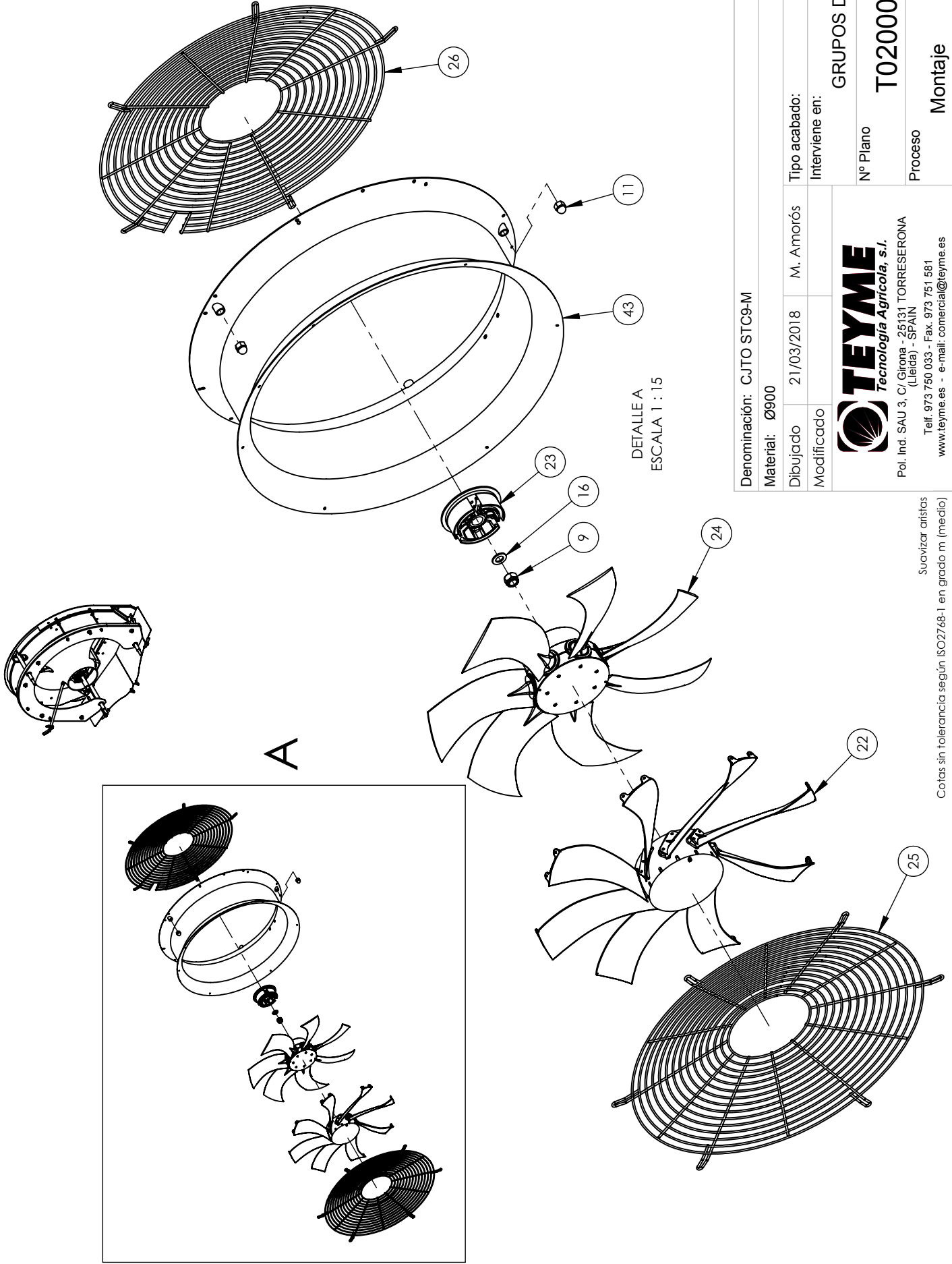

A



DETALLE A  
ESCALA 1 : 15

Denominación: C.JITO STC9-M		Nº hoja: 1/3
Material: Ø900		Peso: 172.72kg
Dibujado: 21/03/2018	M. Amorós	Tipo acabado: -----
Modificado:		Interviene en:
<b>GRUPOS DE AIRE</b>		
Nº Plano: T020000012		ESCALA: 1:40
Proceso: Montaje		Versión: 00
 <b>TEYME</b> Tecnología Agrícola, s.l. Pol. Ind. SAU 3, C/ Girona - 25131 TORRESERONA (Lleida) - SPAIN Telf. 973 750 033 - Fax. 973 751 581 www.teyme.es - e-mail: comercial@teyme.es		

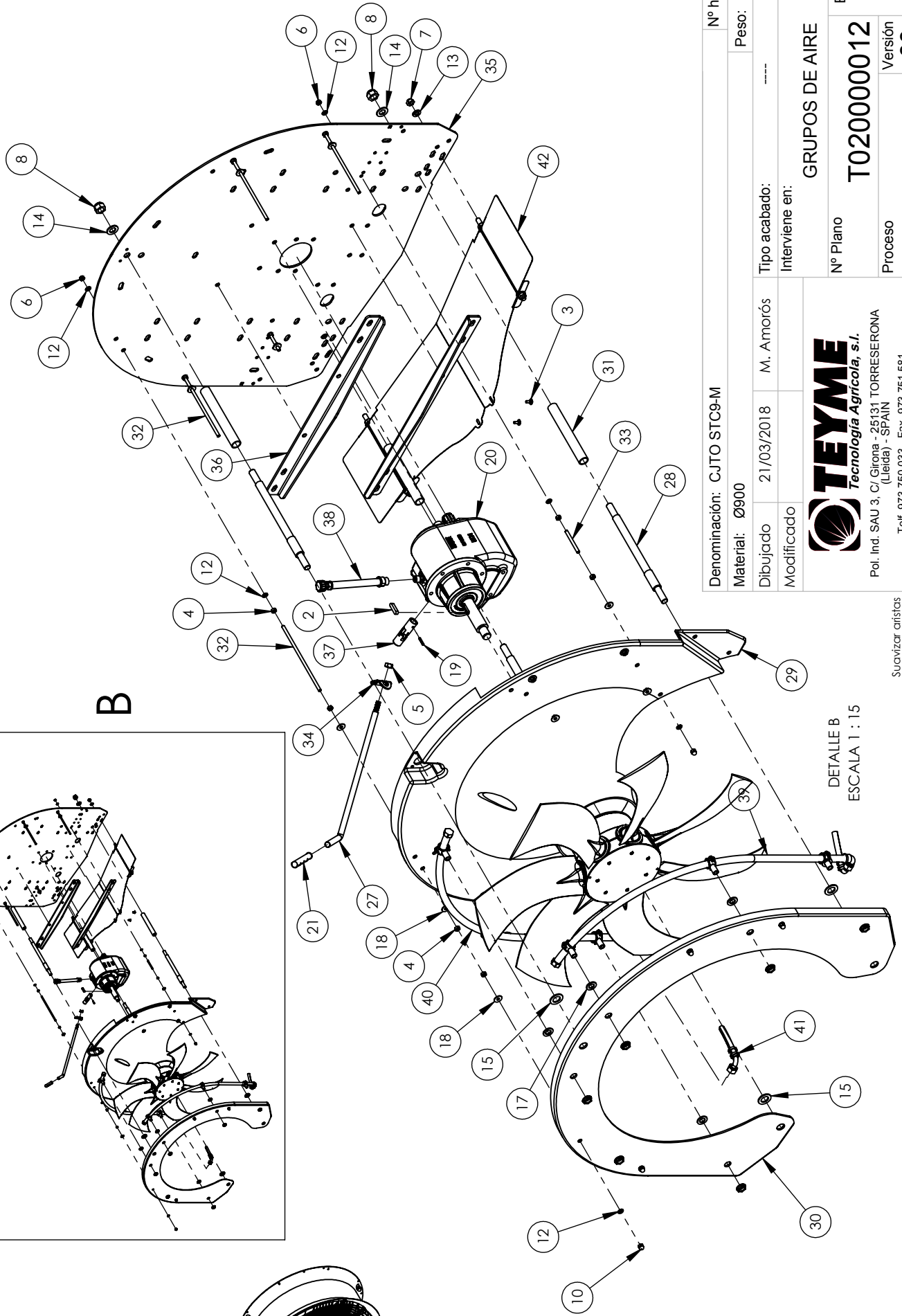
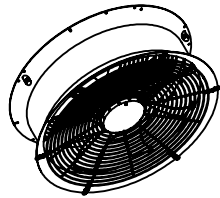
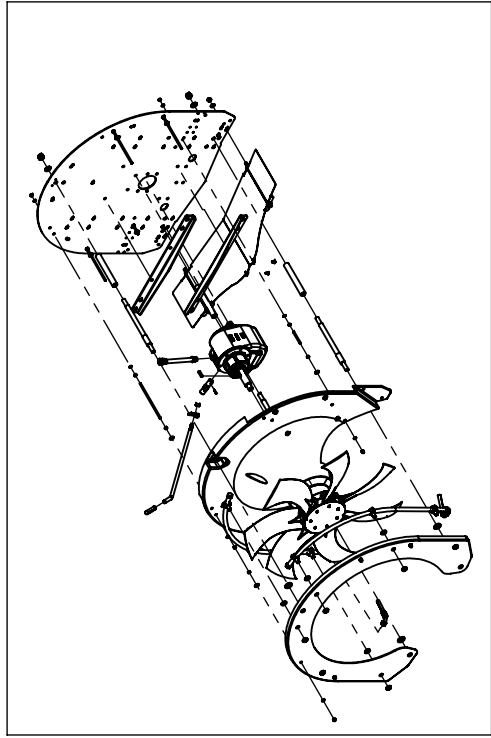
Suavizar aristas según ISO2768-1 en grado m (medio)  
 Este plano es propiedad de TEYME Tecnología Agrícola, S.L. Prohibida su reproducción y cesión a terceros.



DETALLE B  
ESCALA 1 : 15

Denominación: C.JITO STC9-M		Nº hoja: 2/3
Material: Ø900		Peso: 172.72kg
Dibujado	21/03/2018	M. Amorós
Modificado		
Tipo acabado:		Interviene en:
		GRUPOS DE AIRE
Nº Plano		T020000012
Proceso		Montaje
Versión		00
 <b>TEYME</b> Tecnología Agrícola, s.l.		ESCALA 1:40
Pol. Ind. SAU 3, C/ Gitona - 25131 TORRESERONA (Lleida) - SPAIN Telf. 973 750 033 - Fax. 973 751 581 www.teyme.es - e-mail: comercial@teyme.es		

Cotas sin tolerancia según ISO2768-1 en grado m (medio)  
 Suavizar aristas

Este plano es propiedad de TEYME Tecnología Agrícola, S.L. Prohibida su reproducción y cesión a terceros.

## ST9C FAN

Nº	CODE	DESCRIPTION
1	0010140002	1/2" BRASS NUT
2	0270011008	DIN-6885 A 10x8x40 KEY
3	0502500616	DIN-603 INOX M6x16 SCREW
4	0520100800	DIN-934 8.8 Zn M8 NUT
5	0520101200	HEX. DIN-934 M12 ZN NUT
6	0521100800	D-985 AUTOBL. Zn M8 NUT
7	0521101200	D-985 AUTOBL. Zn M12 NUT
8	0521101800	D-985 AUTOBL. Zn M18 NUT
9	0521102200	HEX. DIN-985 M24 ZN NUT
10	0522100800	D-1587 NICKEL. M8 NUT
11	0522110018	DIN 1587 M18 BRASS NUT
12	0550100008	D-125 Zn Ø8 FLAT WASHER
13	0550100012	D-125 Zn Ø12 FLAT WASHER
14	0550100018	D-125 Zn Ø18 FLAT WASHER
15	0550100022	DIN-125 M22 FLAT WASHER
16	0550100024	DIN-125 M24 FLAT WASHER
17	0550120016	D-125 INOX D.16 WASHER
18	0550150008	D-9021 Zn Ø8 WASHER
19	0650010626	DIN-1481 D.5x30 LOCKING PIN
20	1160020121	DV3600 2 VEL 1:3,5 - 1:4,2 M LIFTMOUNTED GEAR BOX
21	2331000002	SHIFT LEVER KNOB
22	2400040600	34" PVS DEFLECTOR
23	2400040602	MEC BIG ZAMAK CLUTCH SET
24	2400040606	34" FULL PLASTIC FAN 7 ARS WITHOUT ADAPTER
25	1140020023	GTE-10 FAN SUCTION GRID
26	1140020025	Ø34" i-STAR & STAR EXIT GRID PAINTED
27	2250160028	GTU8 -GEAR BOX SHIFT LEVER Zn
28	2250250084	GTC9E SHAFT- Zn
29	2331000277	TURBO GTU8/E - 9E MEC CONE
30	2331000293	GTC9/E RAL 7001 POLYETHYLENE CHANNEL
31	2250280054	Zn GTC9 MID CHANNEL DIVIDER SLEEVE
32	3000200800	DIN-975 INOX A2 M8 THREADED ROD
33	3000200800	DIN-975 INOX A2 M8 THREADED ROD
34	2000400497	SHIFT LEVER HOLDER
35	2000500338	PRINCIPAL PLATE
36	T020300021	GTC9 ST MODEL 22 JETS - PAINTED REINFORCEMENT
37	1202000105	Zn PTO SHAFTGEAR SHIFT CROSSHEAD
38	2400045610	OIL FILLING HOSE KIT
39	2400045868	GTC9 RIGHT ARCH KIT
40	2400045869	GTC9 LEFT ARCH KIT
41	2400308016	FEEDING HOSE KIT
42	T020000013	GTC9 DEFLECTORS KIT
43	2400048533	Ø34"x14"UNIC INOX BLOWER HOUSING KIT

N	N_pieza	Denominación	Cantf.	Proceso	Peso
1	0130010040	MANOMETRO INOX. 1/4 0-40 VERT RES. 2bar.	1	Compra Std	0.09
2	B00966	MANDO BY MATIC 50 C/MANOMETRO	1	Compra Std	1.20
3	2400040312	CJTO. SOPORTE MANDO MANUAL COMET - Zn	1	Soldadura	0.38

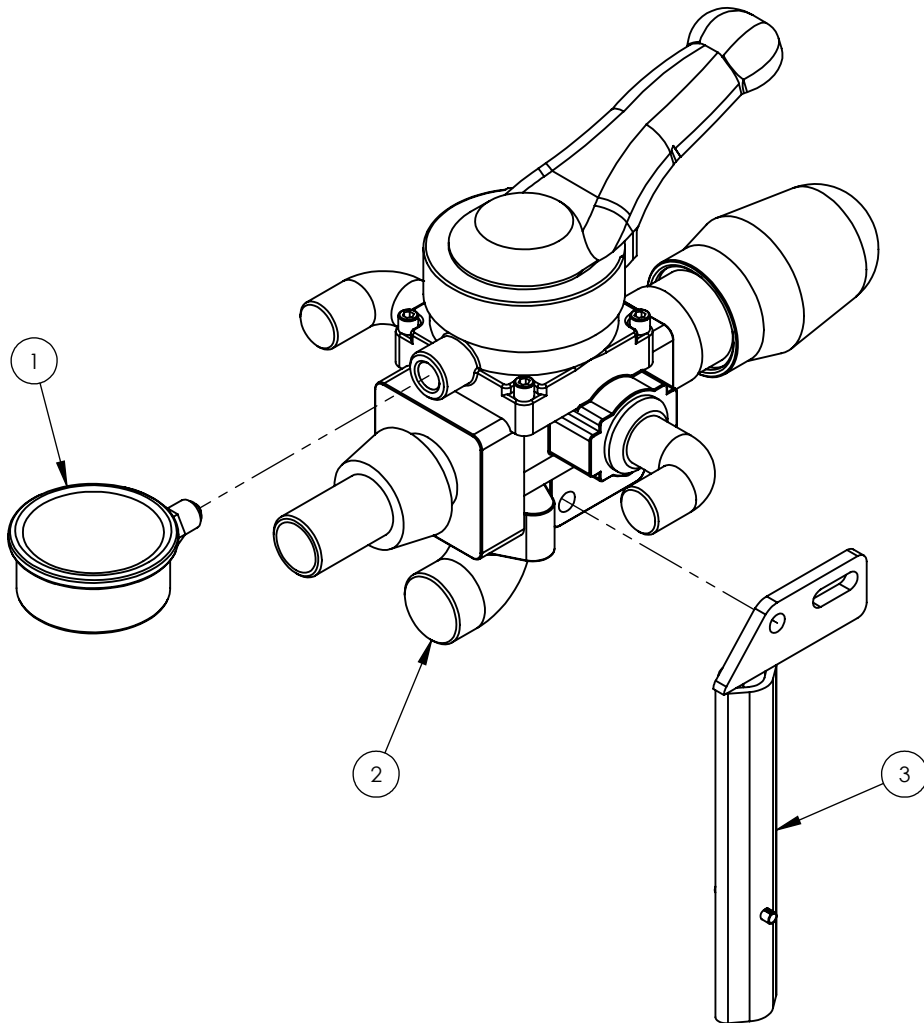

Denominación: CJTO. MANDO DISTANCIA COMET				Nº hoja: 1/1	
Material:				Peso: 1.67kg	
Dibujado	27/11/2018	M. Amorós	Tipo acabado: ----		
Modificado			Interviene en: EQUIPOS POLIETILENO		
 Pol. Ind. SAU 3, C/ Girona - 25131 TORRESERONA (Leida) - SPAIN Telf. 973 750 033 - Fax. 973 751 581 www.teyme.es - e-mail: comercial@teyme.es			Nº Plano	2400041640	ESCALA
			Proceso	Montaje	Versión

Suavizar aristas  
Cotas sin tolerancia según ISO2768-1 en grado m (medio)

## MECHANICAL CONTROL

Nº	CODE	DESCRIPTION
1	0130010040	PSI PRESSURE GAUGE
2	B00966	MECHANICAL CONTROL
3	2400040312	MECHANICAL CONTROL HOLDER

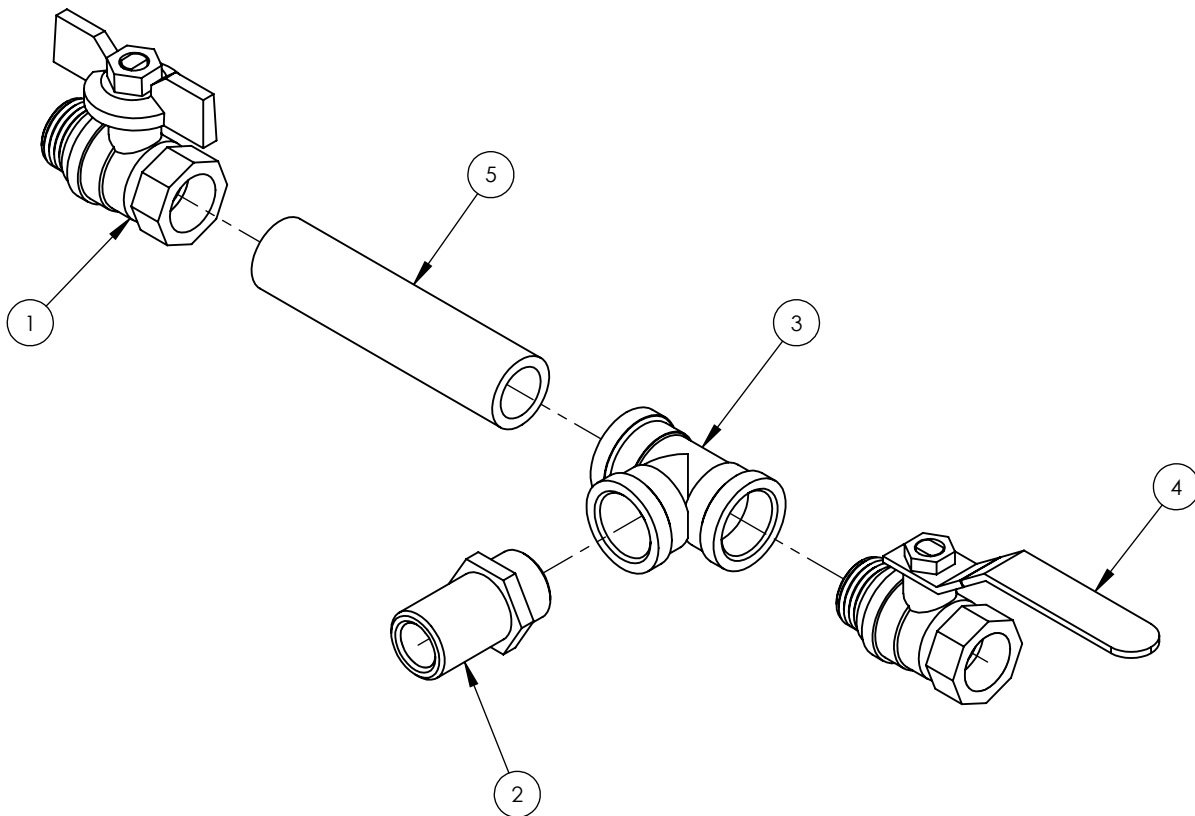

N	N_pieza	Denominación	T A DRETA	Proceso	Peso
1	0170010002	VALV.ESFERA M-H 1/2 T3000-MAR	1	Compra Std	0.16
2	0010030003	UNION LATON M-M 1/2" LARGA	1	Compra Std	0.06
3	0010120001	RACOR LATON T H-H-H 1/2	1	Compra Std	0.09
4	0170010001	VALV.ESFERA M-H 1/2 T3000-PALANCA	1	Compra Std	0.13
5	T010515001	MECHA 1/2" PASAMUROS CHASIS 1516	1	Mecanizado	0.13

Denominación: SCJTO GRIFO PISTOLA 2/3/4000 Nº hoja: 1/1

Material: Peso: 0.62kg

Dibujado 06/09/2018 M. Amorós Tipo acabado: ----

Modificado 03/12/2018 M. Amorós Interviene en:

ATOMIZADORES ARRASTRADOS



Pol. Ind. SAU 3, C/ Girona - 25131 TORRESERONA (Leida) - SPAIN

Tel. 973 750 033 - Fax. 973 751 581  
www.teyme.es - e-mail: comercial@teyme.es

Nº Plano **2400140469** ESCALA **1:2**  
Proceso **Montaje** Versión **01**



Suavizar aristas  
Cotas sin tolerancia según ISO2768-1 en grado m (medio)



## THREE WAYS TAP KIT

Nº	CODE	DESCRIPTION
1	0170010002	M-H 1/2" T3000 BALL VALVE
2	0010030003	M-M 1/2" LONG BRASS UNION
3	0010120001	H-H-H 1/2" T HOSE FITTING
4	0170010001	M-H 1/2" T3000 LEVER VALVE
5	T010515001	1/2" FRAME BULKHEAD UNION







Pol. Ind. SAU III · C/ Girona, 3  
25131 TORRE-SERONA (Lleida) · SPAIN

T: (+34) 973 75 00 33

F: (+34) 973 75 15 81

[comercial@teyme.es](mailto:comercial@teyme.es)



[www.teyme.es](http://www.teyme.es)